

SUPER[®] INOX

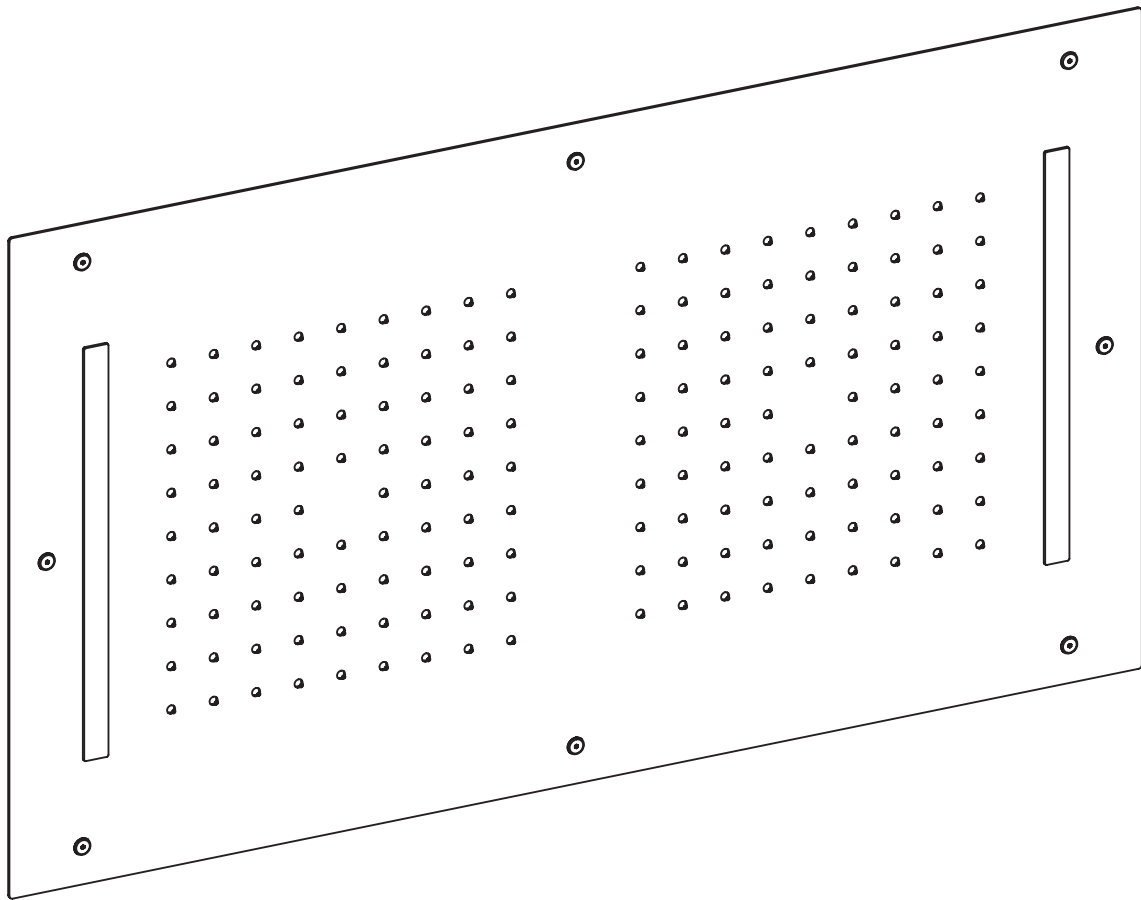

Made in Italy

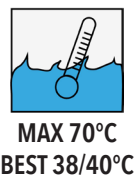
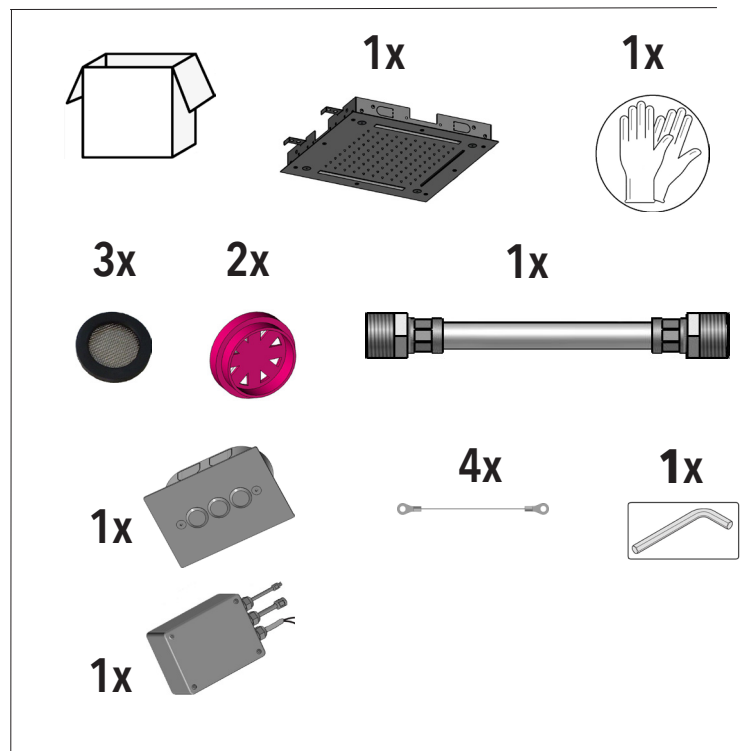
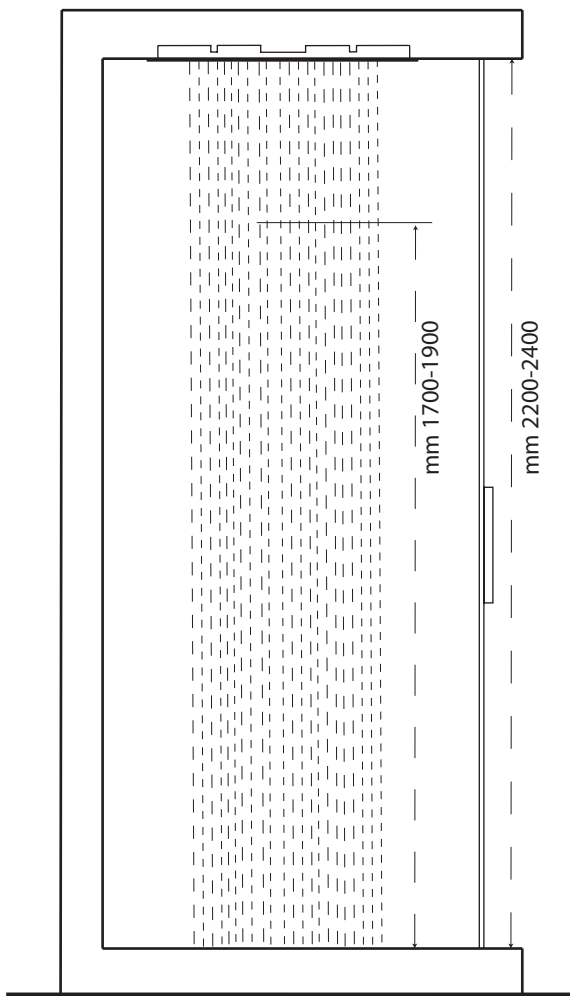
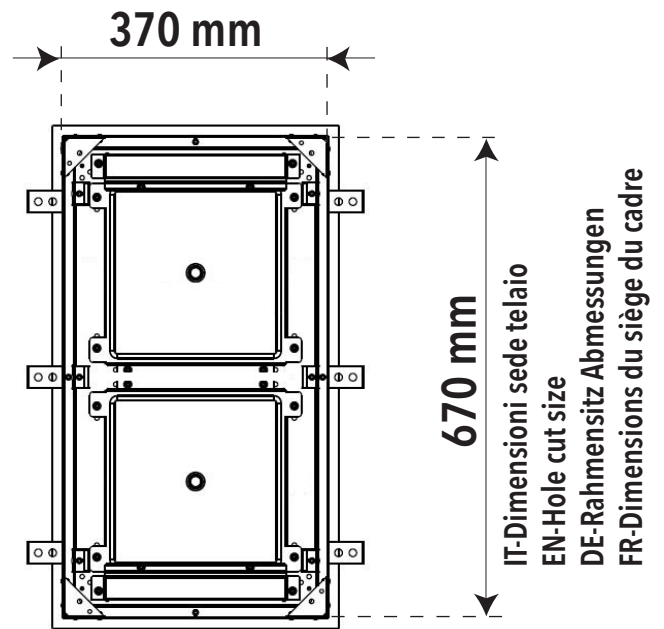
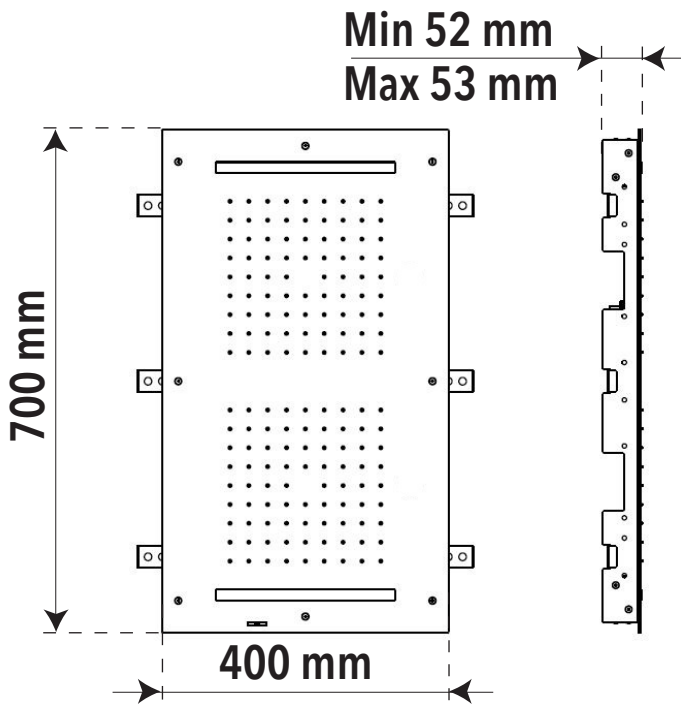

IT - L'apparecchio deve essere installato da personale abilitato ai sensi e per l'effetto delle leggi in vigore.

EN - According to the law, all installation and maintenance operations require a qualified person.

DE - Das Gerät muss von qualifiziertem Personal gemäß den geltenden Gesetzen installiert werden.

FR - L'appareil doit être installé par du personnel qualifié conformément et pour l'effet des lois en vigueur.

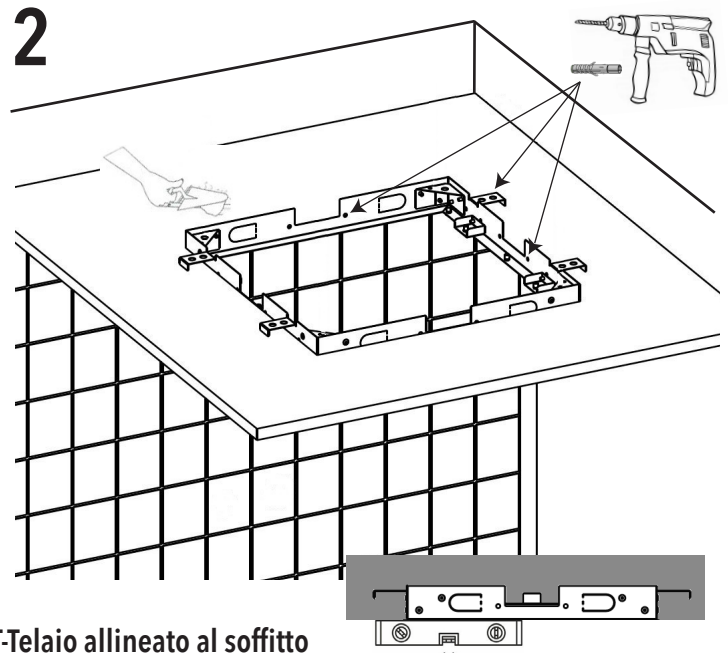
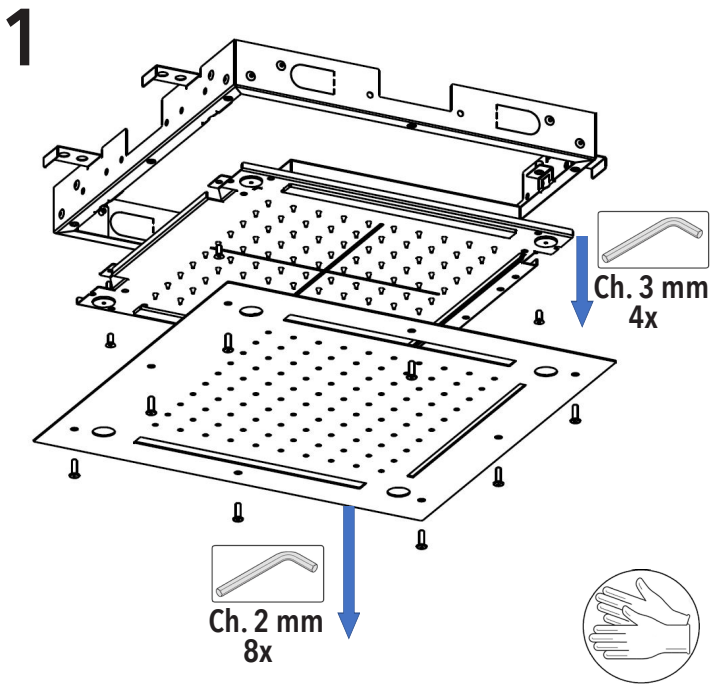

IT-Telaio allineato al soffitto
 EN-Align frame to ceiling
 DE-Rahmen aus der Decke ausgerichtet
 FR-Installez le cadre bien aligné au plafond

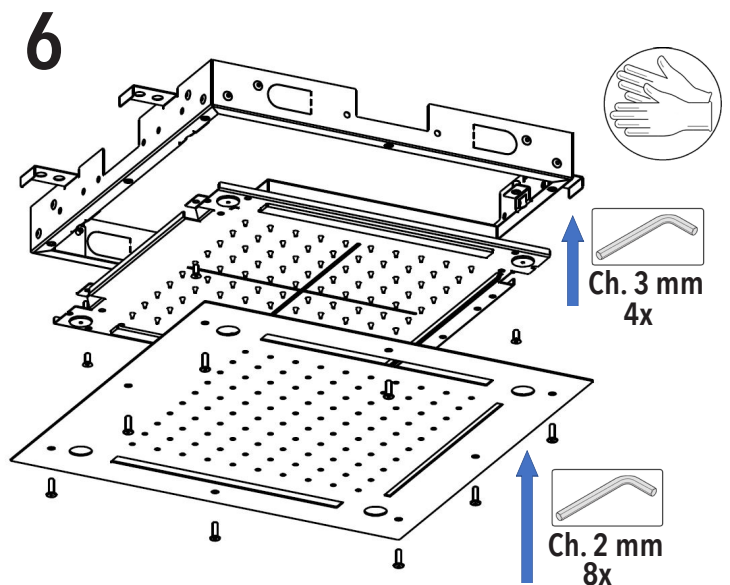
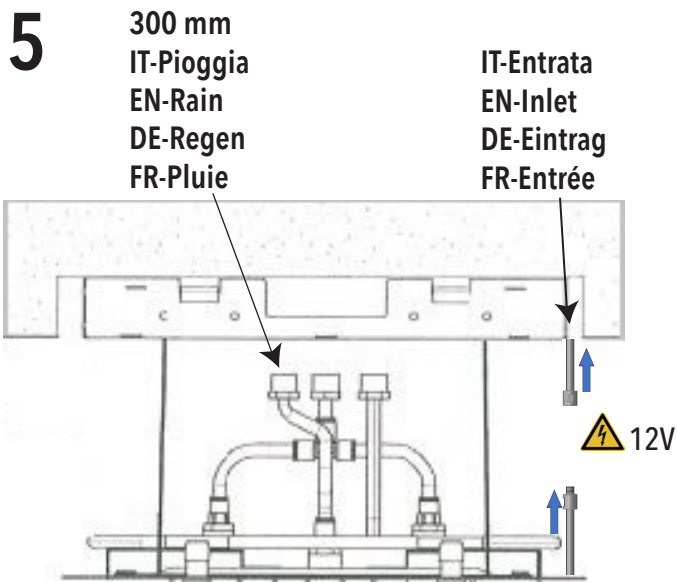
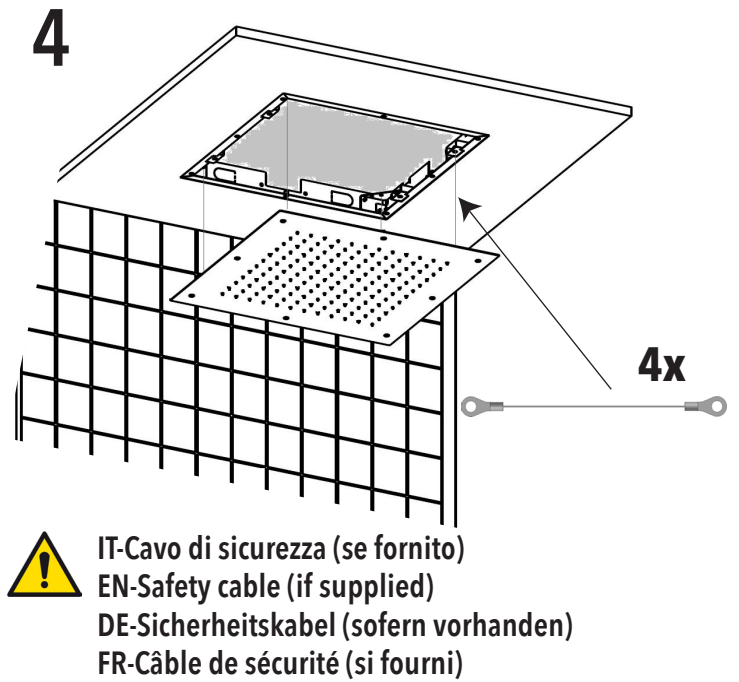
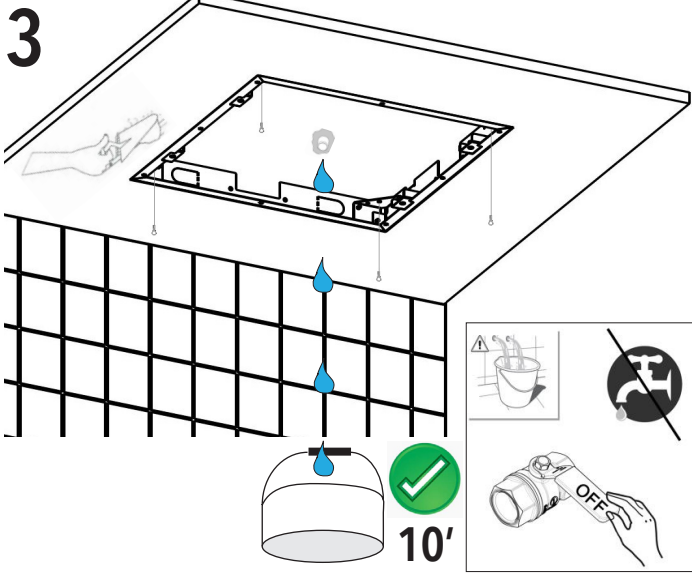

CROMOTERAPIA - CHROMOTHERAPY - FARBTHERAPIE - CHROMOTHÉRAPIE

IT - Comando incasso a muro

EN - In-wall control

DE - Wandeinbau

FR - Commande encastrée au mur



IT - Prima di qualsiasi operazione togliere sempre la tensione all'impianto.

EN - Always turn voltage off before performing any operation on the electric system.

DE - Vor jedem Vorgang immer die Spannung der elektrischen Anlage entfernen.

FR - Coupez toujours la tension avant d'effectuer toute opération.

IT - Installare l'alimentatore Class 2 - 12 Vac +/- 3% - Min. 35 VA nella zona 3 conforme alle distanze di sicurezza previste dalle normative CEI.

EN - Install the Class 2 - 12 Vac +/- 3% - Min. 35 VA device in zone 3, as per the IEC regulations about safety distance.

DE - Installieren Sie das Netzteil der Klasse 2 - 12 V DC +/- 3% - Min. 35 VA in Zone 3 gemäß den Sicherheitsabständen, die in den CEI-Vorschriften vorgeschrieben sind.

FR - Installez l'appareil Classe 2 - 12 Vca +/- 3% - Min. 35 VA dans la zone 3 en respectant les réglementations CEI sur la distance de sécurité.

IT - Collegamento elettrico
EN - Electrical connection setup
DE - Aufbau der elektrischen Verbindung
FR - Configuration de la connexion électrique

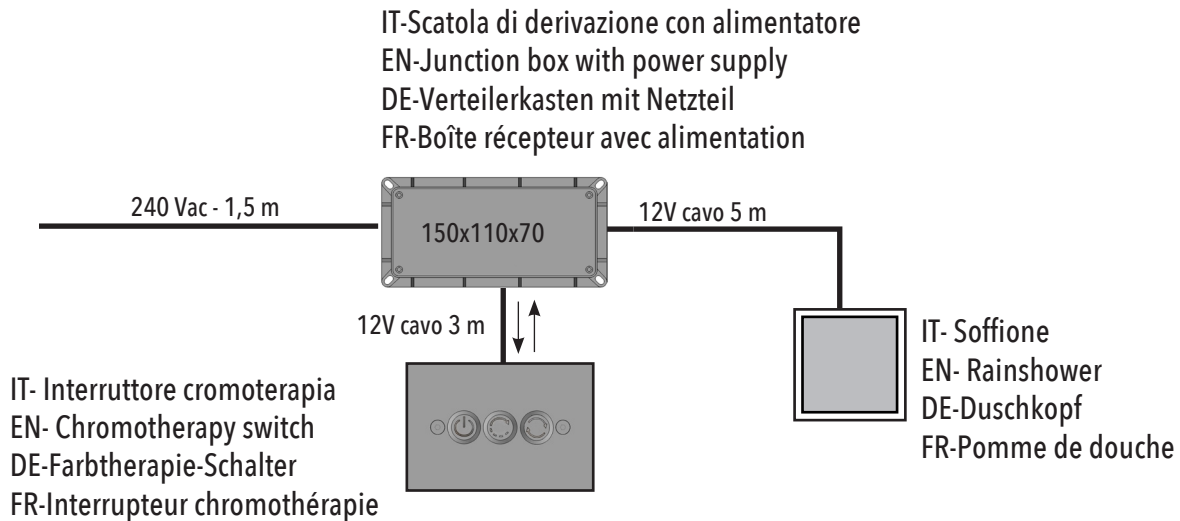

IT-Tensione EN-Voltage DE-Stromspannung FR-Tension	Frequenza Frequency Frequenz La fréquence	Potenza nominale Max. Max. rated power input Max. spezifizierte Leistung Max. puissance d'entrée nominale	Grado di protezione parti elettriche Protection level of electrical parts Schutzgrad für elektrische Teile Niveau de protection des pièces électriques	Grado di protezione pulsante Button protection level Schutzgradknopf Niveau de protection des boutons
100-240 VAC	50-60 Hz	30 W	IP55	IP64

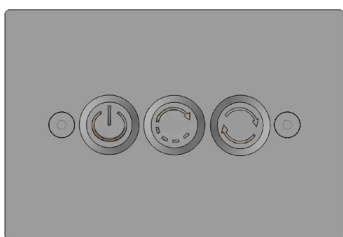

IT-Modalità di funzionamento LED RGB
EN-Mode of operation of the RGB LED
DE-Funktionsweise der RGB-LED
FR-Mode de fonctionnement de la LED RVB

IT - Sequenza colori: Bianco - Rosso - Verde - Blu - Giallo - Fucsia - Azzurro.
 EN- Color sequence: White - Red - Green - Blue - Yellow - Fuchsia - Bright Blue.
 DE-Farbfolge: Weiß - Rot - Grün - Blau - Gelb - Fuchsia - Hellblau.
 FR-Séquence de couleurs: blanc - rouge - vert - bleu - jaune - fuchsia - bleu vif.



-  IT- Tasto ON/OFF
 EN- ON/OFF switch
 DE-Ein-/ Aus-Schalter
 FR-Allumer / éteindre
-  IT- Scelta manuale del colore
 EN- Manual color selection
 DE-Manuelle Auswahl der Farbe
 FR-Choix de couleur
-  IT- Cromoterapia modalità automatica, rotazione colori come sequenza ogni minuto.
 EN- Automatic chromotherapy, color rotation every minute following the sequence above.
 DE-Automatische Farbtherapie, Farbrotaion als Sequenz jede Minute.
 FR-Chromothérapie mode automatique, rotation des couleurs en séquence toutes les minutes.

IT- Predisposizione elettrica
 EN- Electrical setup
 DE- Elektrische Veranlagung
 FR- Installation électrique

IT- Soffione
 EN- Rainshower
 DE- Duschkopf
 FR- Pomme de douche

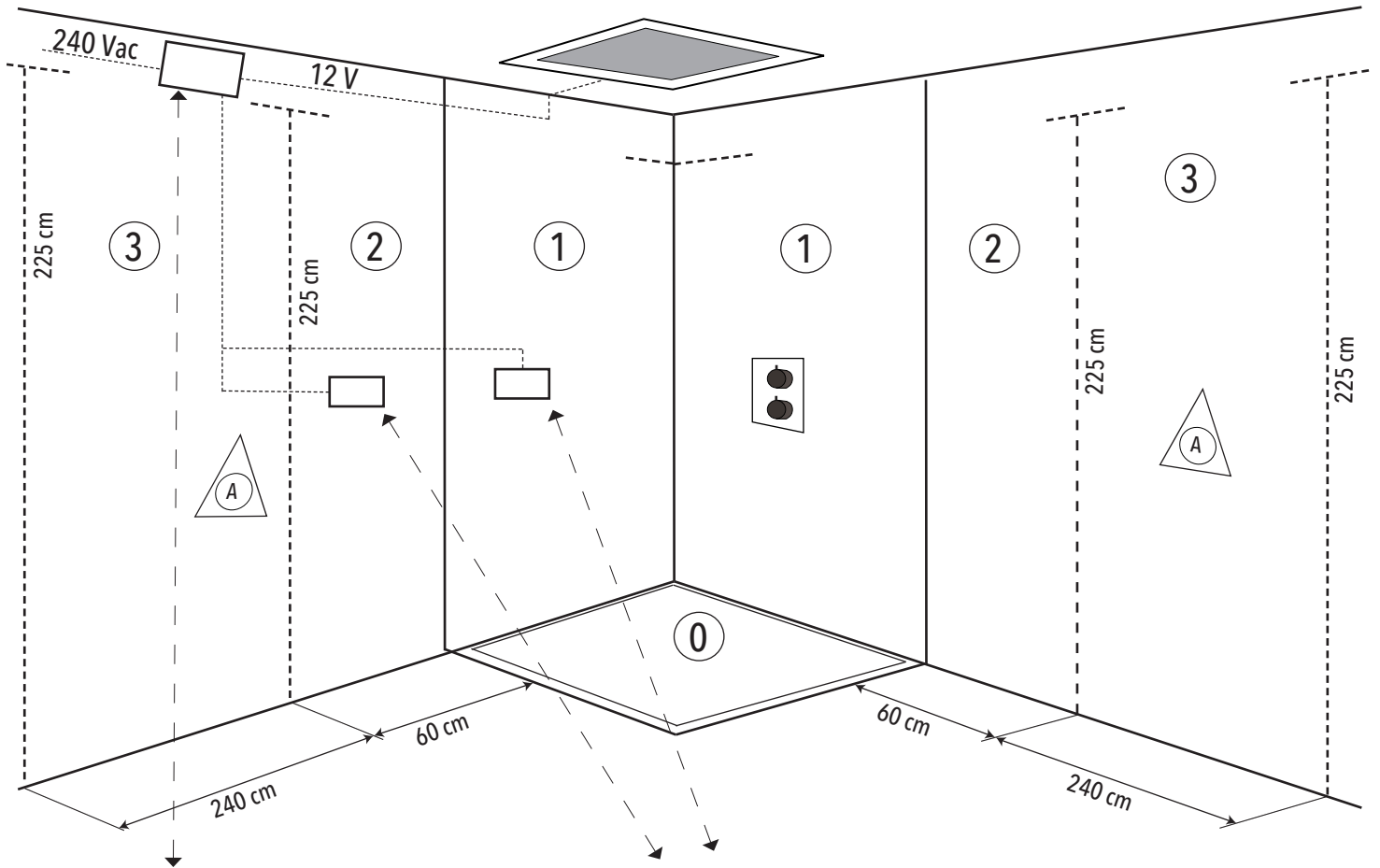

IT- SCATOLA DI DERIVAZIONE

Ipotetica posizione per scatola di derivazione
 (cavo di 1,5 m 240Vac, esterna a cabina doccia).

EN- JUNCTION BOX

Ideal position of the in-wall junction box
 (cable: 1.5 m, 240Vac. outside the shower box).

DE- VERTEILERKASTEN

Bestmögliche Position für Verteilerkasten (1,5 m
 240 VAC Kabel, außerhalb der Duschkabine).

FR- BOÎTE RÉCEPTEUR

Position hypothétique de la boîte de jonction dans
 le mur (câbles de 1,5 m, 240 Vac. l'extérieur de la
 cabine de douche).

IT- Ipotetica posizione per pulsantiera cromoterapia (cavo di 3m 12V).
 EN- Hypothetical position for chromotherapy button panel (3m 12V
 cable).

DE- Hypothetische Position für das Chromotherapie-Tastenfeld
 (3 m 12 V-Kabel).

FR- Position hypothétique du panneau de boutons de chromothérapie
 (câble 12V 3m)



Norme CEI

IEC regulations

IEC-Normen

IT- Zona (3) d'installazione della scatola di derivazione.

EN- Installation area (3) for the junction box.

DE- Gebiet (3) der Installation des Verteilerkasten

FR- Zone d'installation (3) de la boîte de jonction.

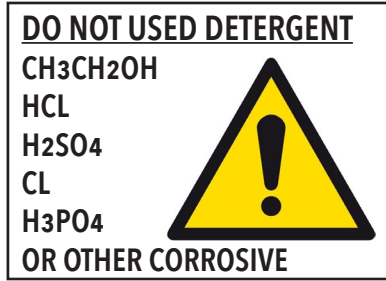

IT - LA GARANZIA DEL PRODOTTO NON COPRE

L'utilizzo improprio.
L'errata predisposizione dell'impianto idraulico.
Danni causati da depositi di calcare o altre impurità.
Detergenti non adatti.

EN - NOT COVERED BY PRODUCT CARE

Not correct use.
Incorrect setup of the hydraulic system.
Water impurities or limestone deposits.
Improper detergents.

DE - DIE PRODUKTGARANTIE GILT NICHT

Die falsche Verwendung
Die falsche Anordnung des Hydrauliksystems.
Schäden durch Kalkablagerungen oder andere
Verunreinigungen.
Ungeeignete Reiniger.

FR - LA GARANTIE DU PRODUIT NE COUVRE PAS

Utilisation incorrecte.
La mauvaise disposition du système hydraulique.
Dommages causés par des dépôts de calcaire ou
d'autres impuretés.
Nettoyants inappropriés.



IT - DUE ANNI DI GARANZIA DEL PRODOTTO

Contro i difetti o vizi di fabbricazione.

EN - TWO-YEAR PRODUCT CARE

Against defects of fabrication.

DE - ZWEI JAHRE LANG PRODUKTGARANTIE

Gegen Mängel oder Herstellungsfehler

FR - GARANTIE DE PRODUITS DE DEUX ANS

Contre les défauts de fabrication.

IT - ATTENZIONE: Si declina ogni responsabilità relativa ad eventuali inesattezze contenute in queste istruzioni dovute ad errori di trascrizione.

EN - WARNING: We decline all responsibility for eventual inaccuracy contained in the instructions due to transcript errors.

DE - ACHTUNG: Wir lehnen jede Verantwortung für Ungenauigkeiten in diesen Anleitung aufgrund von Transkriptionsfehlern ab.

FR - ATTENTION: Nous déclinons toute responsabilité pour toute inexactitude contenue dans ces instructions en raison d'erreurs de transcription.

